



**PISTEHITSAUSTARVIKKEET**  
**2008**

***Teknoexpertit***

Puh. (02) 275 3555, faksi (02) 243 6004

[www.teknoexpertit.fi](http://www.teknoexpertit.fi)

## PISTEHITSAUSKÄRJET 1-9

Sekalaiset kärjet .....	1
Kartio Ø 12 -10 %.....	2
Kartio Ø 18 -10 %.....	3
Malli 38.....	5
Malli 37.....	6
Malli 36.....	7
Malli 87.....	8
Pistehitsaushatut ja hatunpitimet .....	9
VESIJÄÄHDYTTIESET KÄRJENPITIMET .....	10

## LISÄKSI VALIKOIMASSAMME:

- pistekoneen varsia
- kiekkoaihioita
- kiekkohitsauslangat
- elektrodimateriaalit pyörö- ja suorakaidetankoina
- lamellipaketit
- elektrodin irroitusavain
- eristenauha
- kärjenteroittimet käsi- ja paineilmatoimiset
- puristuspainemittarit
- jalkapoljin

Kartio: Ø 8.9 -10 %

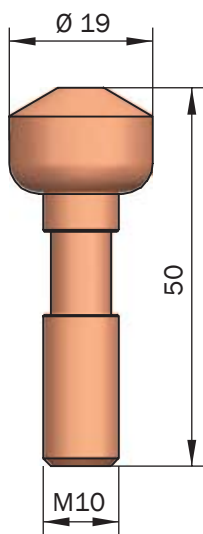
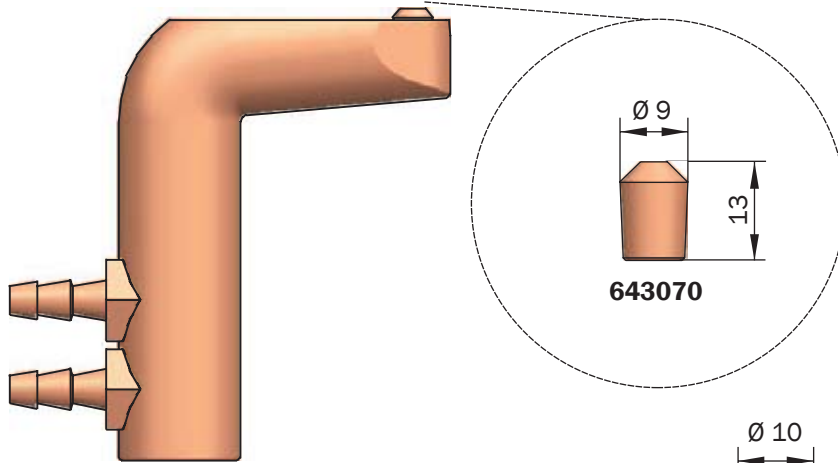

643138

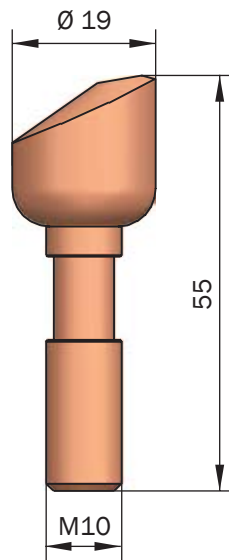

643139

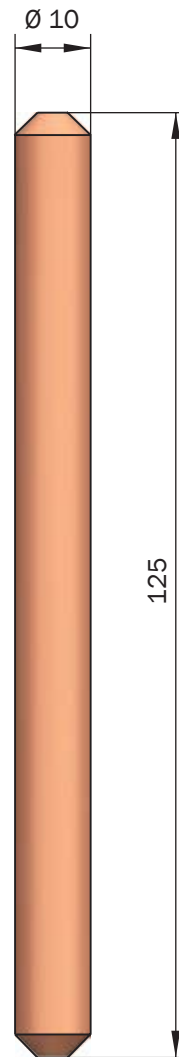

643054

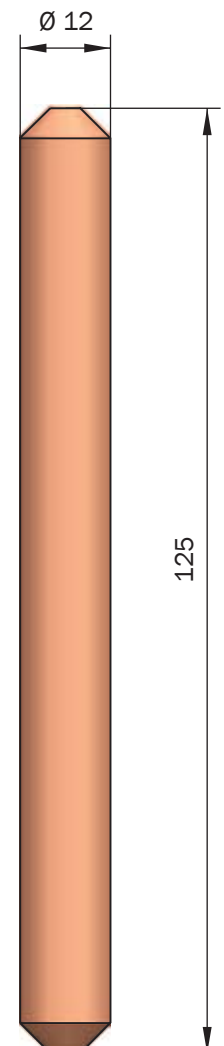

643054A

Kartio: Ø 12 -10 %

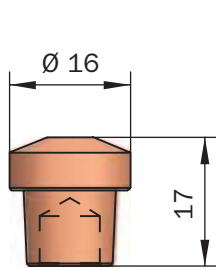

643117

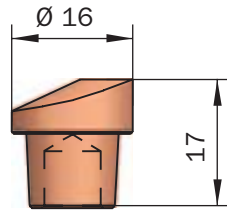

643116

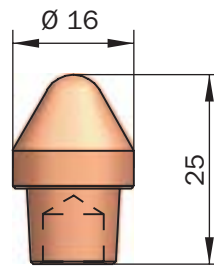

643091

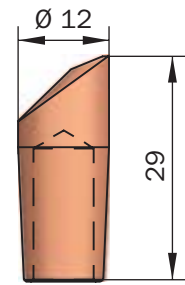

643080

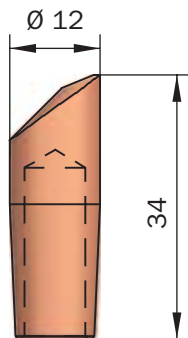

643081

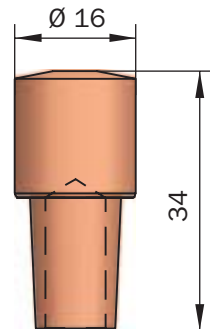

643083

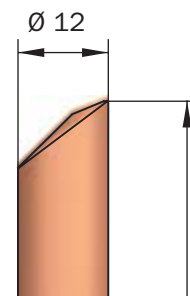

643085

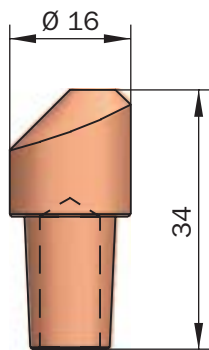

643084

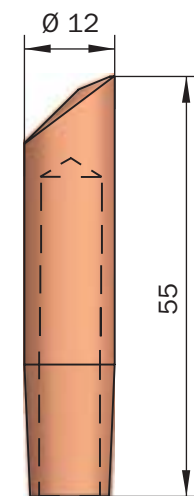

643082

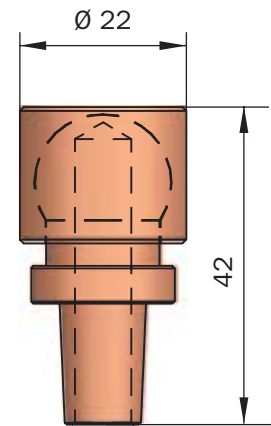

643092

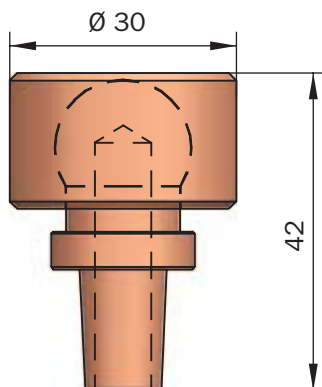

643093

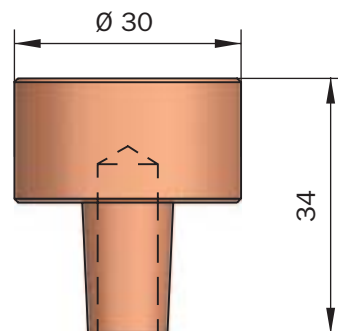

643094

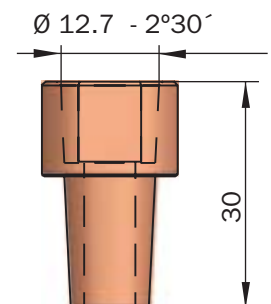

643129

Kartio: Ø 18 -10 %

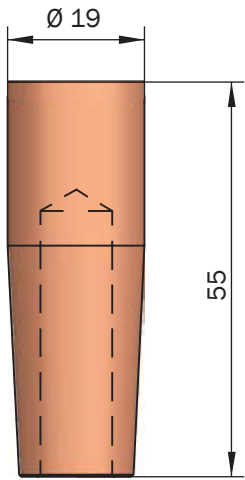

643140

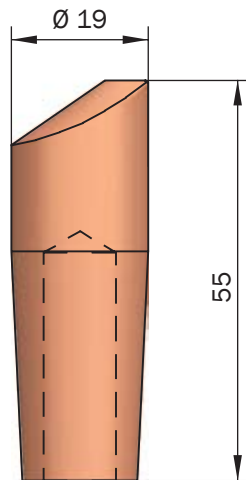

643143

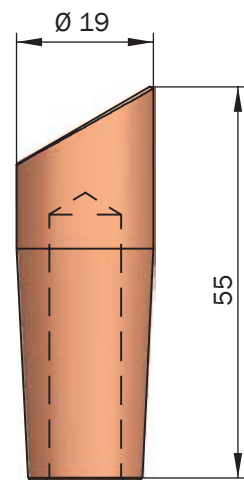

643144

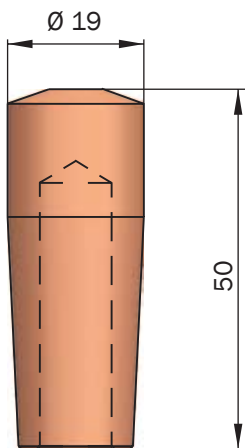

643145

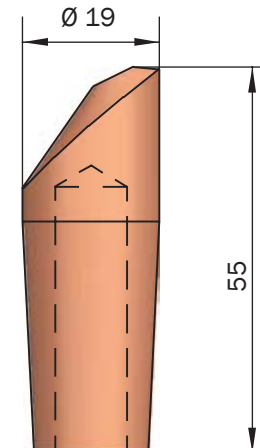

643146

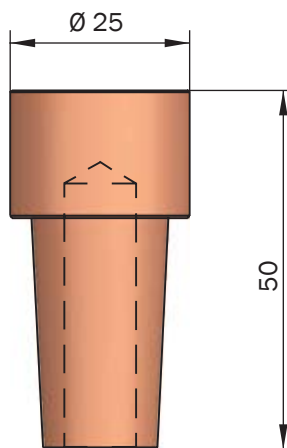

643149A

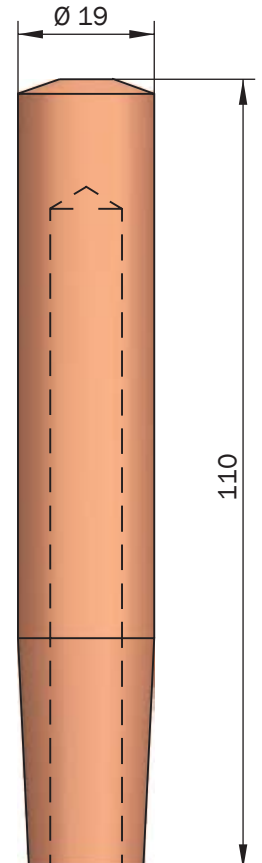

643145L

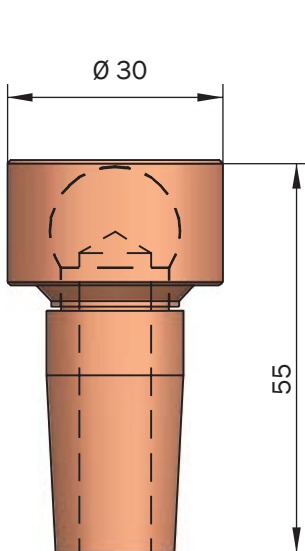

643148

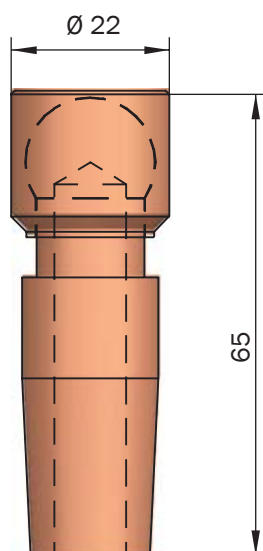

643149

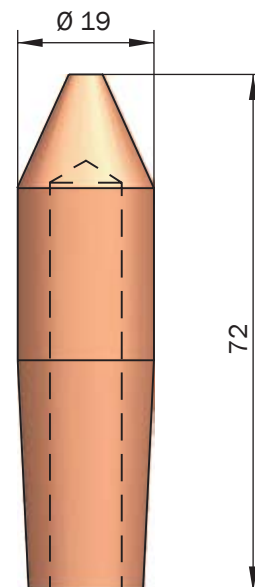

643150

Kartio: Ø 18 -10 %

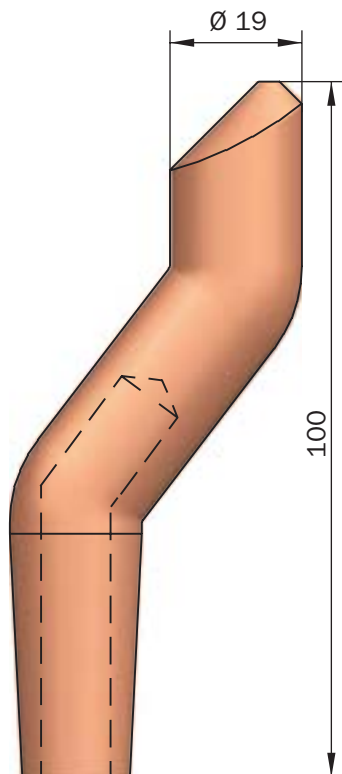

643147

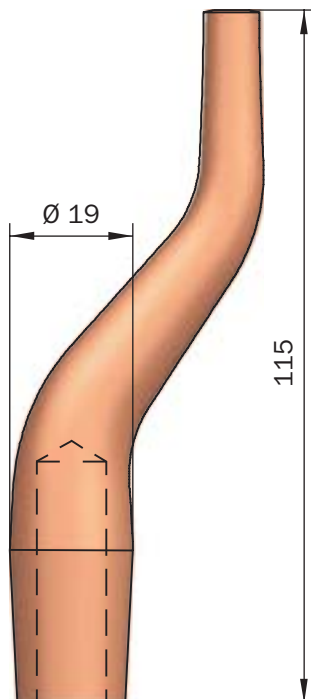

643151

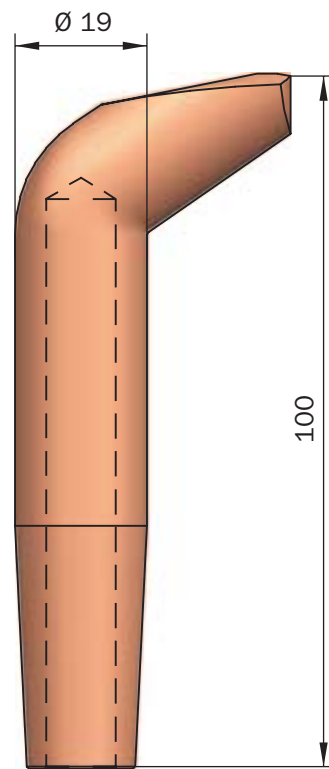

643154

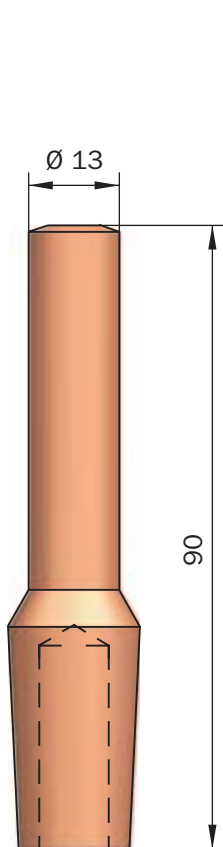

643152

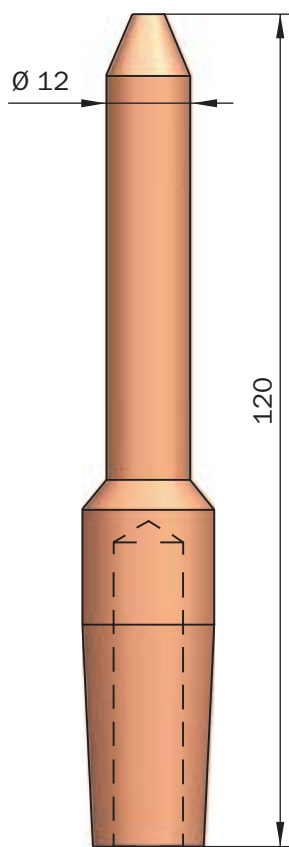

643155

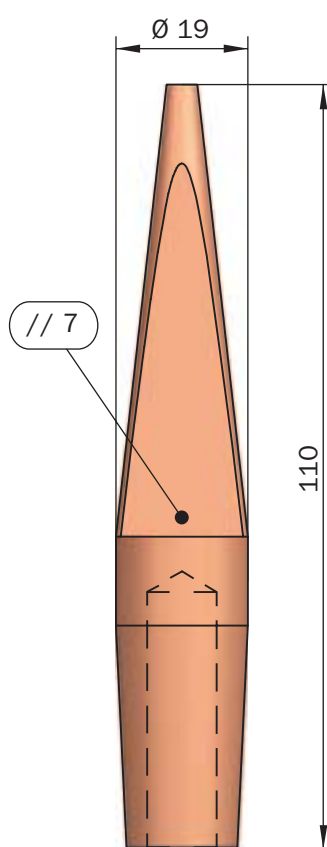

643155A

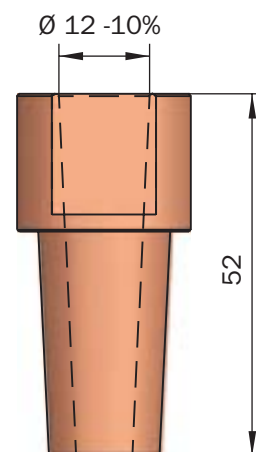

643157

MALLI 38. Kartio:  $\varnothing 10.7 -2^{\circ} 30'$

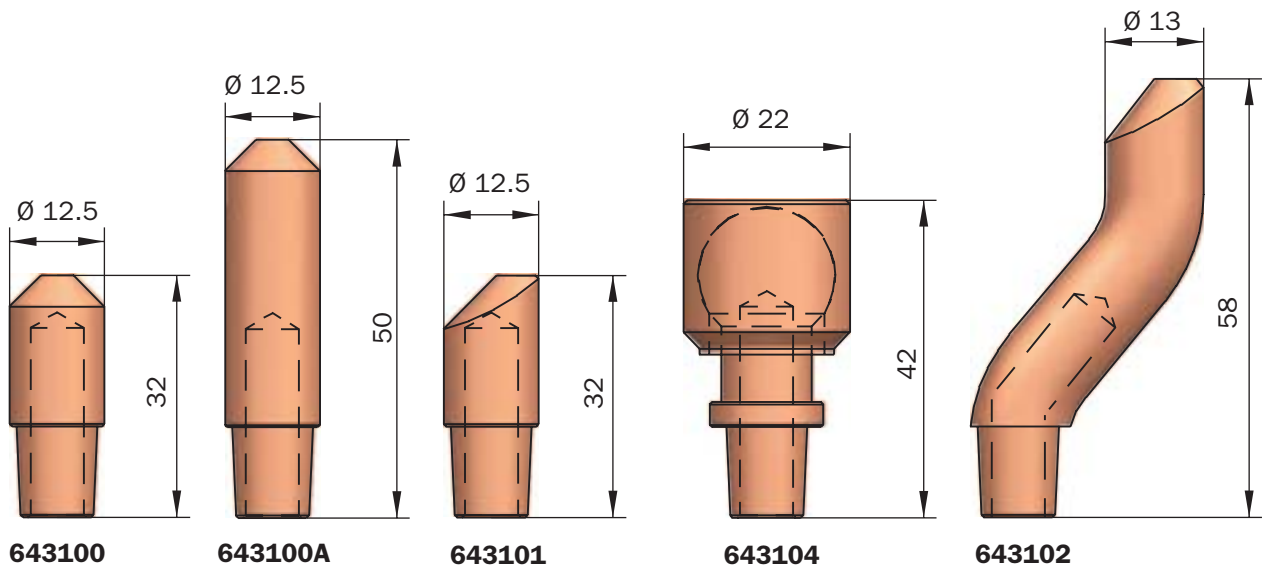

MALLI 37. Kartio: Ø 12.7 -2° 30'

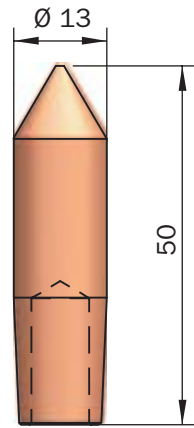

643110C

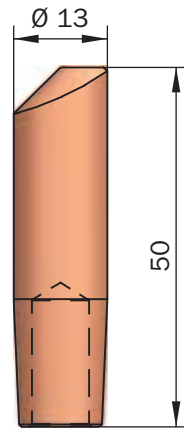

643111D

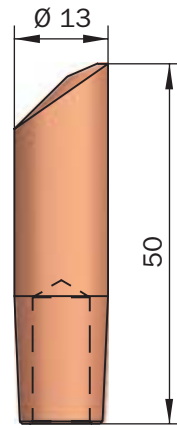

643111B

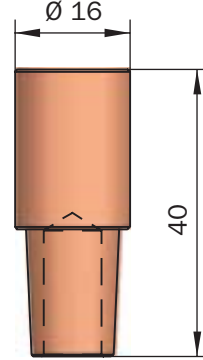

643112

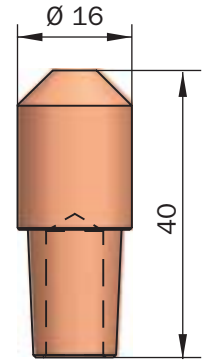

643110

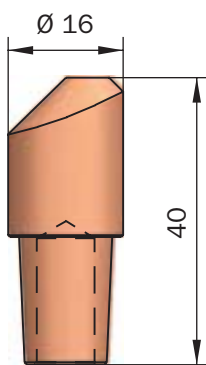

643111A

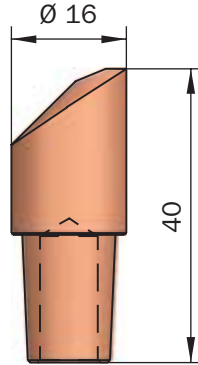

643111

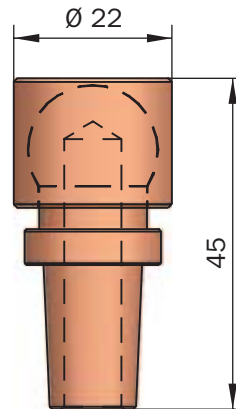

643114A

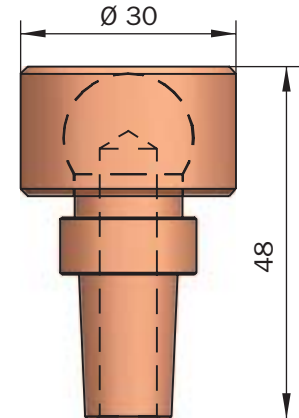

643114

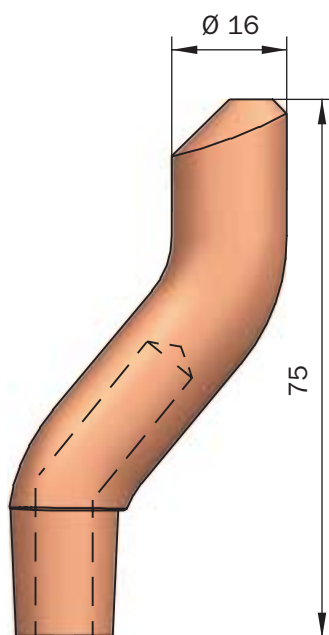

643113

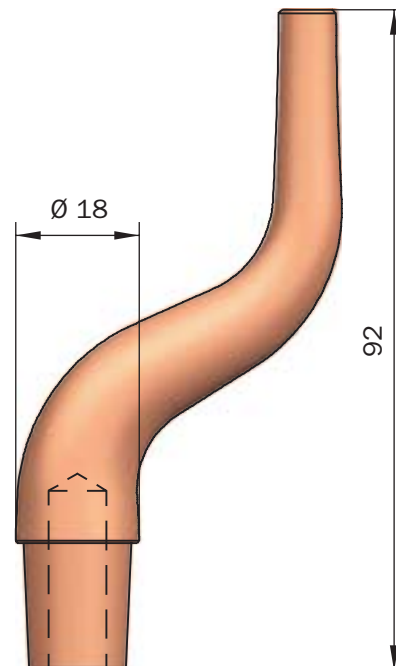

643113A



MALLI 36. Kartio:  $\varnothing 14.8 - 2^\circ 30'$

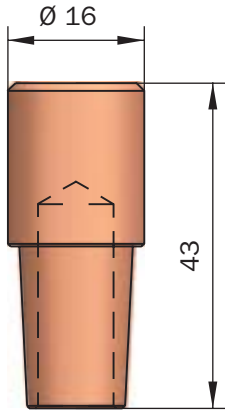

643123

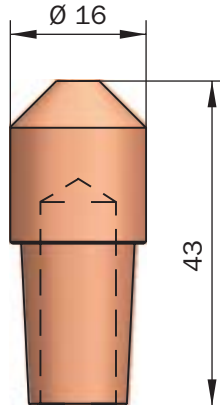

643120

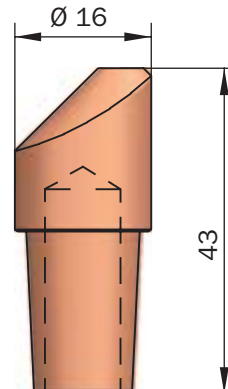

643121

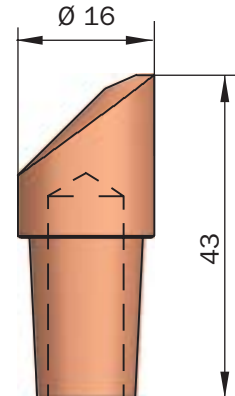

643121A

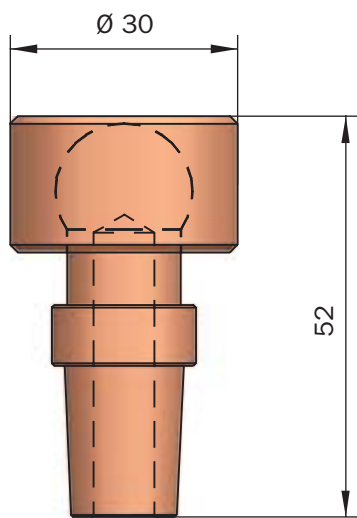

643124

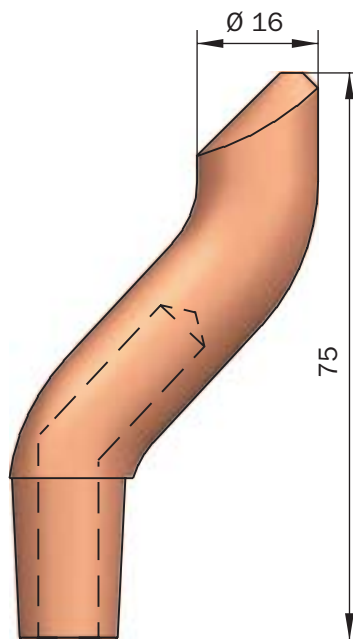

643122

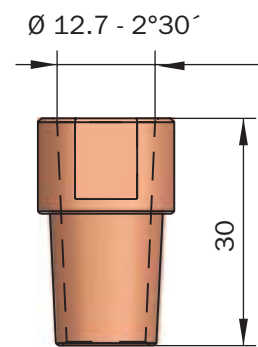

643127

MALLI 87. Kartio:  $\varnothing 19$   $-2^{\circ}30'$

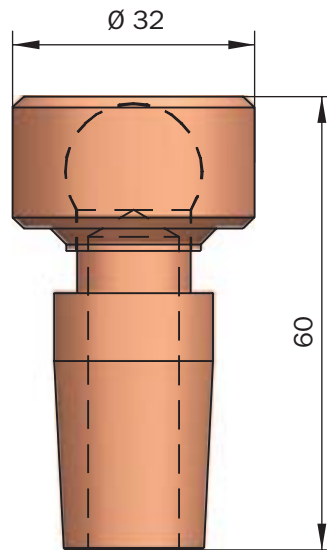

643148A

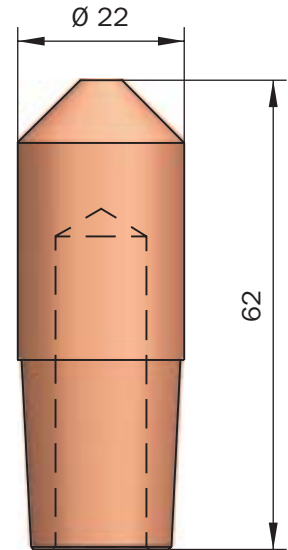

643350

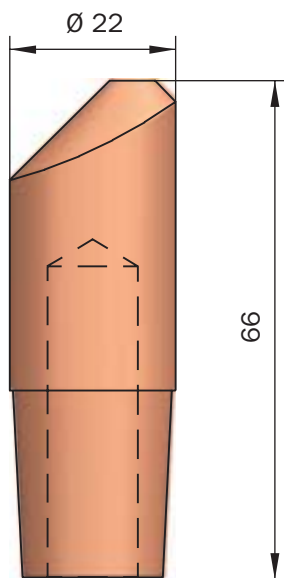

643352

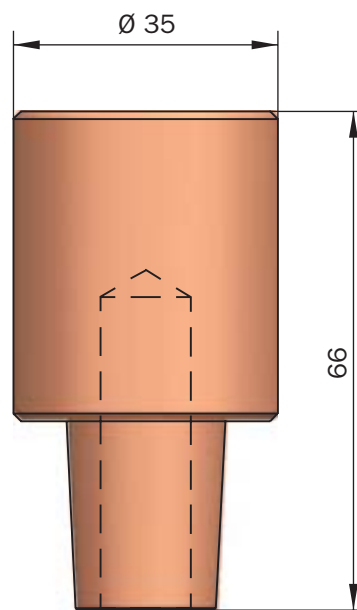

643353

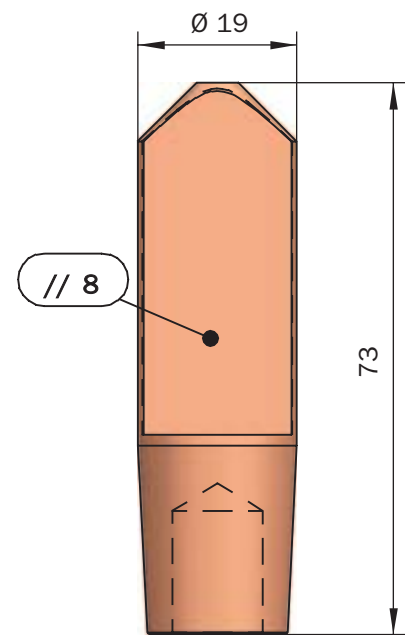

643359

# PISTEHITSAUSHATUT JA HATUNPITIMET 9

Materiaali: CuCrZr

**Kartio: -10 %** Hattujen halkaisijat  $\varnothing$  13 ja 16

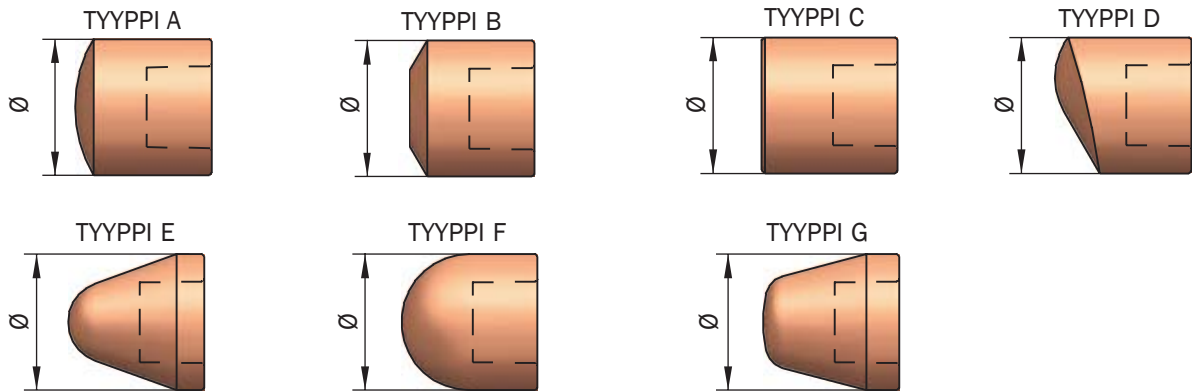

Tilattaessa mainittava hatun tyyppi ja  $\varnothing$ . Esim. Hattu C16.

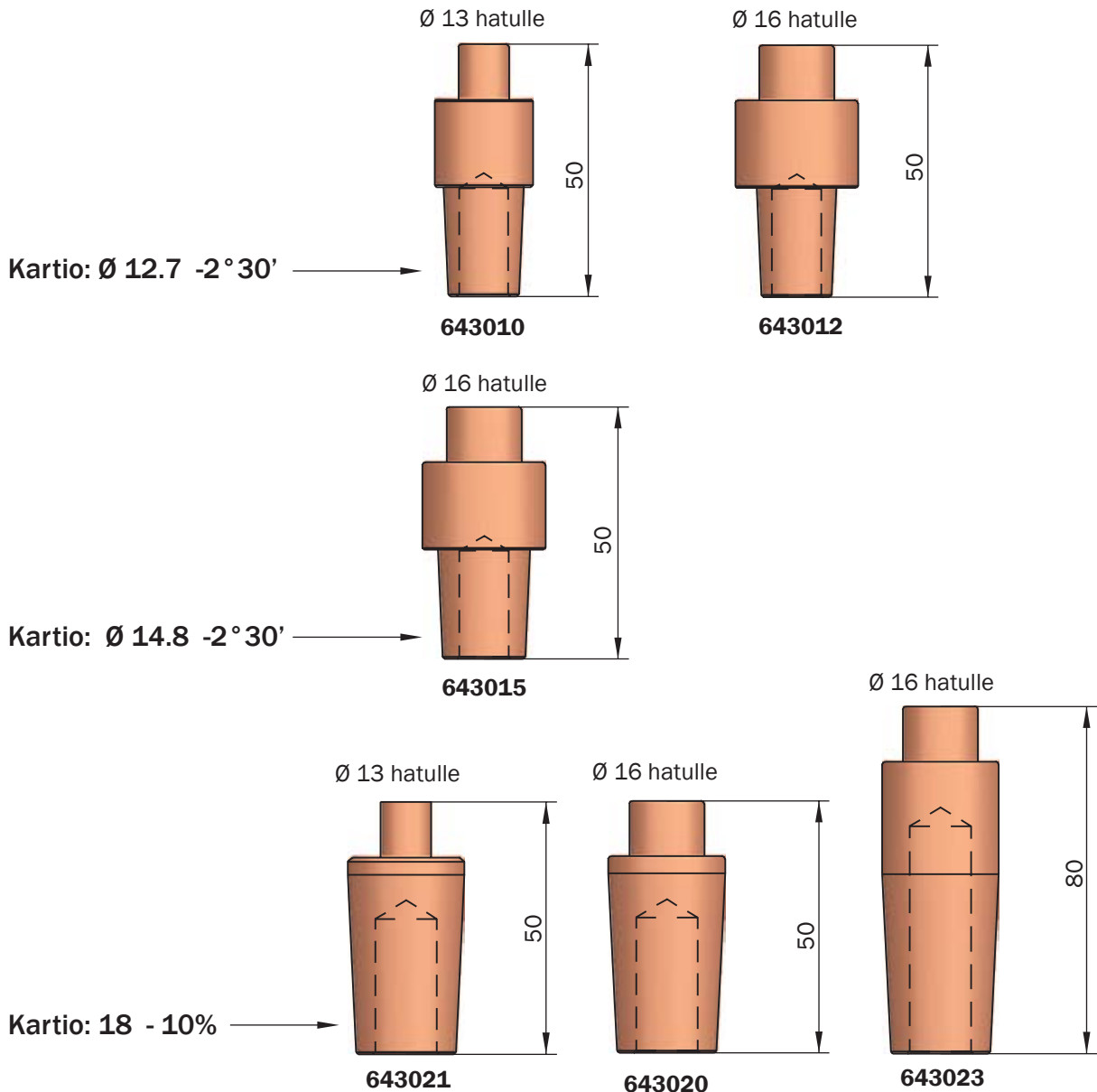

Toimitamme kärjenpitimiä:

- halkaisijat 14 - 35 mm
- pituudet 45 - 500 mm

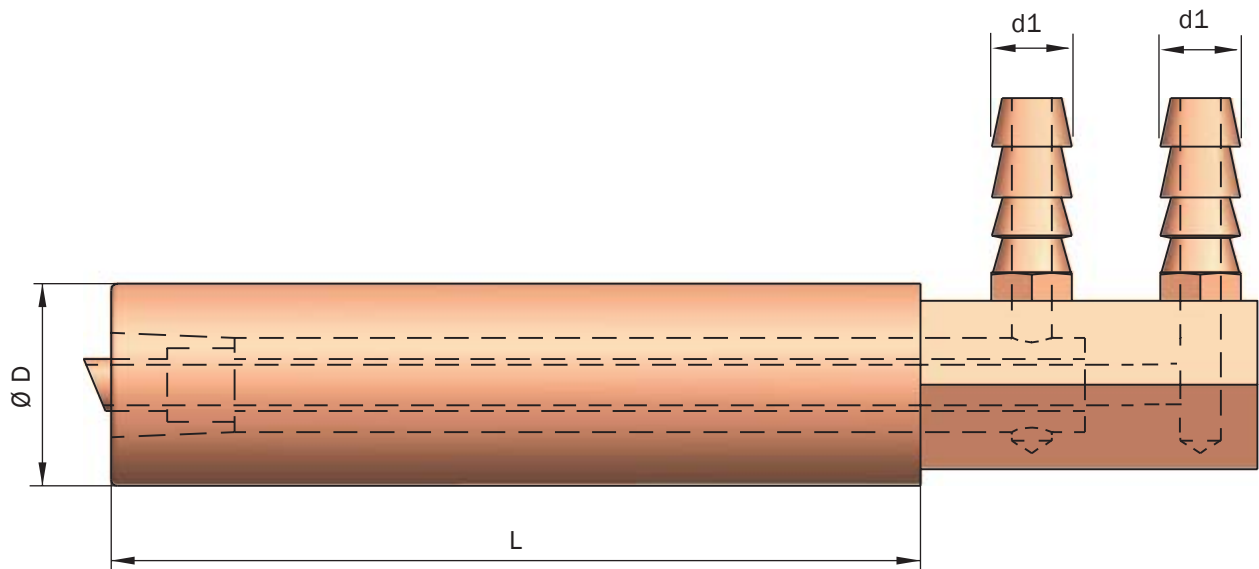

Tilattaessa mainittava Ø, L ja kärjen kartio. Esim. Ø 18 - 10 %

